



Armstrong® STEAMIX® Steam & Water Hose Stations & Mixing Units

Model 2033—Standard

STEAMIX 203 Steam/Water Mixing Valve of brass/stainless steel (SS) construction.

STEAMIX® Model 2033 is supplied as standard with 3/4" inlet union connections with integral strainers, an outlet ball valve for flow control and an outlet dial thermometer. The unit is supplied fully assembled, pressure-tested and installed on a stainless steel hose rack.

STEAMIX Model 2033 includes 25 feet of "safety yellow" washdown hose, rubber cushioned spray nozzle with swivel adapter and a stainless steel nozzle hook.



Locking set (included)



Safety Features

- **Steamix 203 will not pass live steam.** In the event of either a complete failure of the inlet cold-water supply or a reduction in cold-water pressure to below 20 (+/-5) psi (1.4 bar), STEAMIX will respond with a complete shutdown of outlet flow.
- If there is a structural failure of the primary operating component (diaphragm), STEAMIX will "fail safe" to cold water.
- To prevent over-temperature selection by the user and the potential for overheated water and flash steam presentation common with other types of hose stations, STEAMIX is supplied with a single-temperature locking set.

Technical Specifications

- 3/4" (20 mm) NPT inlets/outlet(s)
- Brass/stainless steel construction
- Operating pressures
 - Maximum: 150 psi (10 bar)
 - Minimum: 20 psi† (1.4 bar)
- Maximum pressure loss ratio 10:1††
- Inlet check valves required
- Weight: 56 lbs (25 kg) with 25 ft hose
66 lbs (30 kg) with 50 ft hose

† **IMPORTANT NOTE: Lower steam pressures significantly reduce outlet flow rates.**

†† Ratio of inlet pressures accounting for restrictions on valve outlet (minus back pressure).

Flow Rates

The capacity charts indicate STEAMIX 203 flow rates at steam and water pressures commonly available in the average manufacturing plant. The STEAMIX 203 can handle a wide diversity of pressures and temperatures. Three typical outlet temperatures shown in the flow tables were selected to demonstrate the valve's flow rate at:

- A) "User safe" temperature (approx. 120°F - 48°C)
- B) "Hot hose down" temperature (approx. 150/160°F - 65/71°C)
- C) "Common bacteria kill" temperature (approx. 180°F - 82°C)

NOTE: All flow rates shown are with open outlet, and a reduction of flow is to be expected depending on the length and diameter of outlet pipework, washdown hose, spray nozzle, etc.

For a fully detailed certified drawing, refer to: **CD #2274**

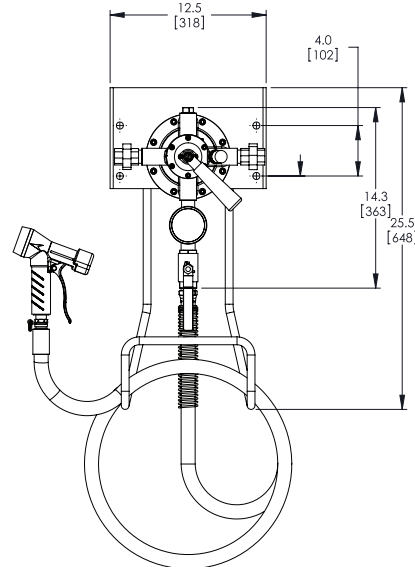

A) 55°F (31°C) Temperature Rise						
Water \ Steam	20 (1.4)	45 (3)	75 (5)	100 (7)	psi (bar)	
22 psi (1.5 bar)	6.9 (26.1)	10.2 (38.6)	10.2 (38.6)	10.2 (38.6)	gal/min (l/min)	
45 psi (3 bar)	6.9 (26.1)	13.2 (49.9)	13.2 (49.9)	13.2 (49.9)	gal/min (l/min)	
60 psi (4 bar)	6.9 (26.1)	13.8 (52.2)	15.7 (59.4)	15.7 (59.4)	gal/min (l/min)	
B) 100°F (56°C) Temperature Rise						
Water \ Steam	20 (1.4)	45 (3)	75 (5)	100 (7)	psi (bar)	
22 psi (1.5 bar)	3.6 (13.6)	6.9 (26.1)	8.3 (31.4)	8.5 (32.1)	gal/min (l/min)	
45 psi (3 bar)	3.6 (13.6)	6.9 (26.1)	9.4 (35.5)	9.9 (37.4)	gal/min (l/min)	
60 psi (4 bar)	3.6 (13.6)	6.9 (26.1)	9.4 (35.5)	10.5 (39.7)	gal/min (l/min)	
C) 135°F (75°C) Temperature Rise						
Water \ Steam	20 (1.4)	45 (3)	75 (5)	100 (7)	psi (bar)	
22 psi (1.5 bar)	2.5 (9.4)	5.0 (18.9)	6.6 (24.9)	7.2 (27.2)	gal/min (l/min)	
45 psi (3 bar)	2.5 (9.4)	5.0 (18.9)	7.2 (27.2)	8.0 (30.2)	gal/min (l/min)	
60 psi (4 bar)	2.5 (9.4)	5.0 (18.9)	7.2 (27.2)	8.0 (30.2)	gal/min (l/min)	

All dimensions and weights are approximate. Use certified print for exact dimensions. Design and materials are subject to change without notice.